



**Analogue KNZD-10 Vandalism Telephone**

**DESCRIPTION ITEM NO.ZD0100012**

1. Stainless steel 304 body, vandal & tamper-resistant hardware, easy installation.
2. Waterproof rating IP55 dust proof.
3. Full keypad with memory, 10 button programmable telephone, support free dial.
4. Magnetic reed hook-switch.
5. Lightening protection to ITU-T recommendation K.21.
6. Heavy duty handset with hearing aid compatible receiver, noise canceling microphone.
7. Handset with industrial strong metal cord.
8. Telephone line powered.
9. SUS keypad keep waterproof and dusty proof.
10. Temperature range from -40 degree to +70 degree.
11. Support echo cancellation, wall mounted installation.
12. Phone integrity wiring comply with most PABX exchange system.
13. Optional 7 minute time out to release the line if the handset is left off hook. (This function upon buyer's requirement).
14. Body in electrophoresis process finish no fingerprint, resistant to corrosion.
15. Application: Prison, bank, airport, school, metro, railway station, LRT, hotel, supermarket and pedestrian areas in cities etc.



## SPECIFICATION

1. PSTN analogue telephone
2. DTMF dialing
3. MTBF:100000hours
4. MTTR: 2 hours
5. Connection: RJ11 screw terminal pair cable
6. Applicable for various types of SPC exchange PABX and dispatching exchange system with feeding voltage of 33-60V.
7. Ambient temperature:-30 ~ +60 degree. Relative humidity:10%~95%  
Atmospheric pressure: 86~106Kpa Circumstance noise:less than60dB(A)
8. Sound level of ringing:over 70dB(A).
9. Standard frequency:low frequency group:697. 770. 852. 941Hz,  
high frequency group:1209. 1336. 1477Hz, frequency deviation:-1.5% ~ +1.5%
- 10.Call transmission index:(5KM)SLR<12,RLR<-1,STMR>10, output impedance is 600 Ohm.  
maximum distance: 7KM
11. Connection: RJ11 screw terminal pair cable (or RJ11 Socket of plug upon request) with stainless steel cable protected

## INSTALLATION

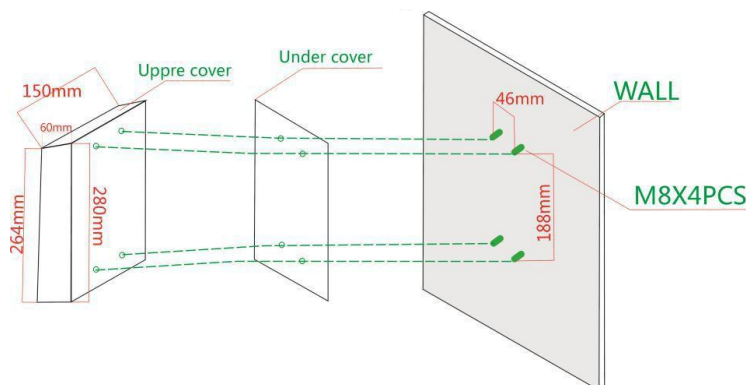

## CERTIFICATION

RCM: AS/NZS CISPR 32      Australian communications:AS/CA S004  
 Australian Equipment-safety: AS/NZS 60950.1:2015  
 EMC: EN50121(Railway application-Electromagnetic Compatibility)



## PACKING



Unit size:280\*264\*60mm Unit: N.W:2.14KG  
 1pcs packing box size: 340\*220\*220mm Unit: N.W:2.14KG    Unit G.W:3KG  
 6pcs in 1 outer Carton box: size: 540\*360\*380mm N.W:12.84KG    G.W:18.5KG

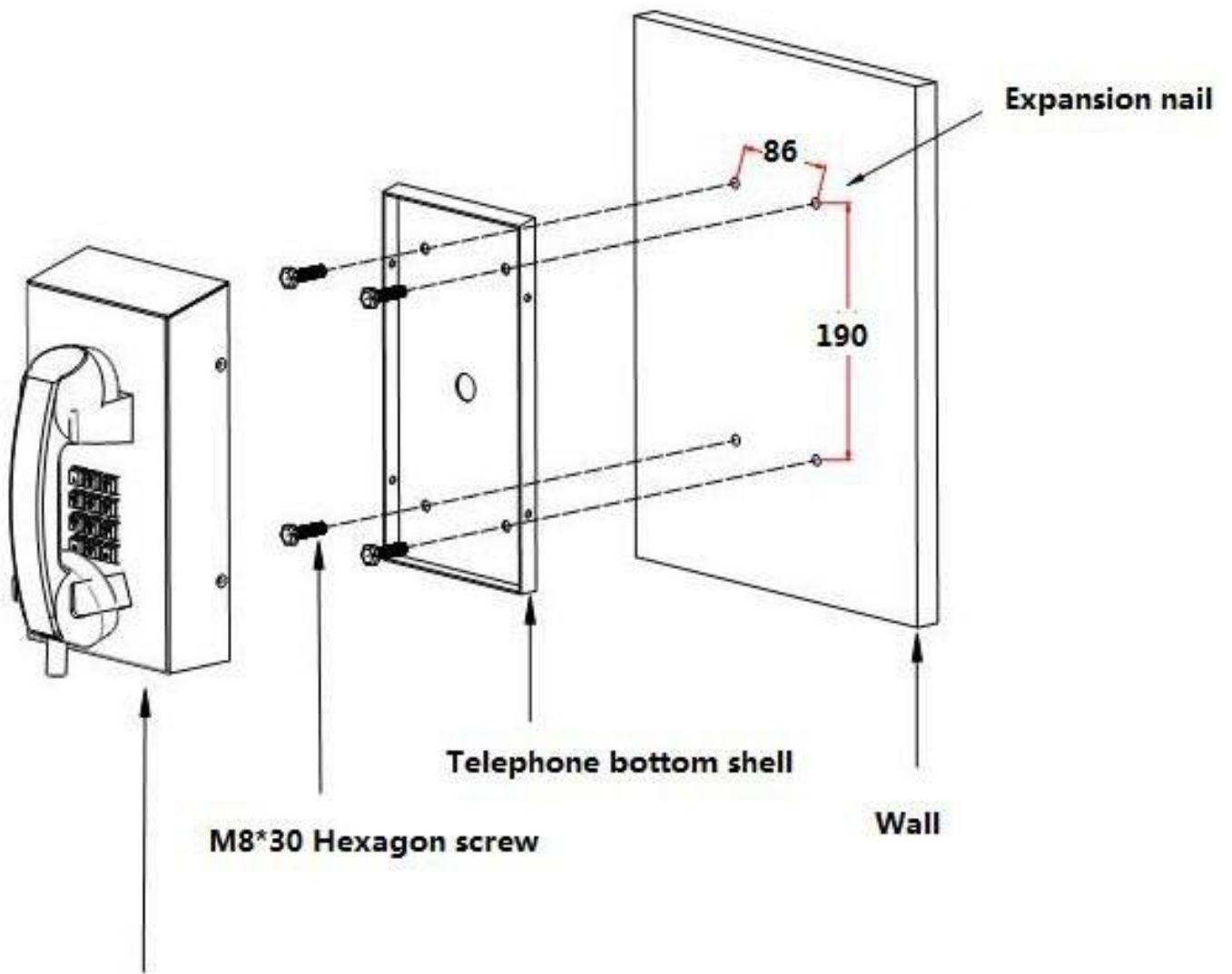

**Unit:mm**

