



## **Analogue KNZD-11 Elevator Telephone**

### **DESCRIPTION ITEM NO.:ZD0110012**

1. Stainless steel 304 body with SUS one push button, vandal & tamper-resistant hardware.
2. Waterproof rating IP55 dust proof.
3. Hands-free, auto-answer and auto-hang up.
4. Service temperature range from -30 degree to +75 degree.
5. Lightning protection to ITU-T recommendation K.21.
6. Support hotline calling.
7. Support echo cancellation.
8. Telephone line powered.
9. Cold-rolled material optional.
10. Body in electrophoresis process finish no fingerprint, resistant to corrosion.
11. Application: Metro, railway, LRT, speedway, bank, university, hotel, clean room, elevator etc.



## SPECIFICATION

1. PSTN analogue telephone
2. DTMF dialing
3. MTBF:100000hours
4. MTTR: 2 hours
5. Connection: RJ11 screw terminal pair cable
6. Applicable for various types of SPC exchange PABX and dispatching exchange system with feeding voltage of 33-60V.
7. Ambient temperature:-30 ~ +60 degree. Relative humidity:10%~95%  
Atmospheric pressure: 86~106Kpa Circumstance noise:less than 60dB(A)
8. Sound level of ringing:over 70dB(A).
9. Standard frequency:low frequency group:697. 770. 852. 941Hz,  
high frequency group:1209. 1336. 1477Hz, frequency deviation:-1.5% ~ +1.5%
10. Call transmission index:(5KM)SLR<12,RLR<-1,STMR>10, output impedance is 600 Ohm.  
maximum distance: 7KM
11. Hotline setting (maximum length of each number is 16 digits)
12. Connection: RJ11 screw terminal pair cable (or RJ11 Socket of plug upon request)  
with stainless steel cable protected

## INSTALLATION

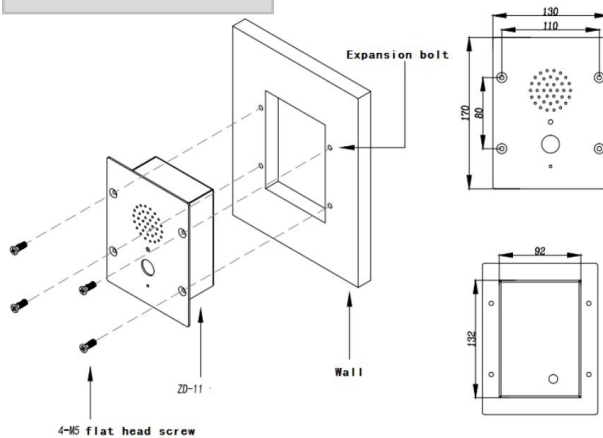

## CERTIFICATION

EN55022: emissions

EN55024: immunity

Ingress Protection: GB4208-93 IP66 FCC

ITU-T Recommendations K21

EMC: EN50121(Railway application-Electromagnetic Compatibility)



RoHS

## PACKING



Unit size:170\*130\*60mm

Unit: N.W:0.65KG

1pcs packing box size: 200\*140\*100mm

Unit N.W:0.65KG Unit G.W:1KG

12pcs in 1 outer Carton box: size: 500\*360\*420mm N.W:7.8KG G.W:13.1KG